

# COMMON MIST COLLECTION METHODS

In order to fully understand why the Royal Filtermist is the best choice for handling oil mist and smoke produced by the metalworking industry, it is important to have some general knowledge of how other types of collection systems work. This section contains an overview of the most common methods for controlling mist and smoke. While these systems all have some positive features, their drawbacks make them unsuitable for use in most metalworking applications.

## External Venting

At one time, the only method for controlling oil mist and smoke in a shop was to vent it out of the building. This was done either by opening the doors and windows or installing a ventilation system. While this method may look like an attractive low-cost solution, the potential dangers should be enough to make any shop owner reconsider this practice.

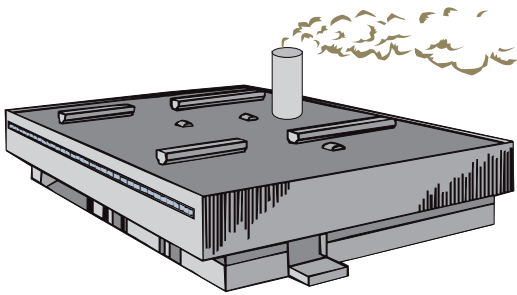

**Environmental Hazards** Today, **it is illegal in many states to exhaust pollutants to the atmosphere.** Offending companies run the risk of large fines and lawsuits.

**Fire Hazards** Over time, oil deposits collect in the ductwork of ventilation systems, making them prime targets for flash fires and providing pathways for fires to spread quickly.

**Cleanliness Problems** As mist and smoke travels through a shop to the exhaust points, it collects on exposed surfaces. Over time, a grimy buildup occurs on machines, lights, floors, and walls, resulting in dirty, unsafe conditions.

## Media-Type Filtration Systems

Media-type filtration systems typically consist of a blower and several filters of varying efficiencies. The contaminated air first passes through a coarse pre-filter where the largest particles are filtered out. It then moves through one or two medium-range filters before reaching the final filter, which is usually made from a high-efficiency HEPA material. Media-type systems are good at collecting dry contaminants such as welding smoke and graphite dust. However, they are often not suitable for metalworking applications where coolant mist is the primary contaminant.

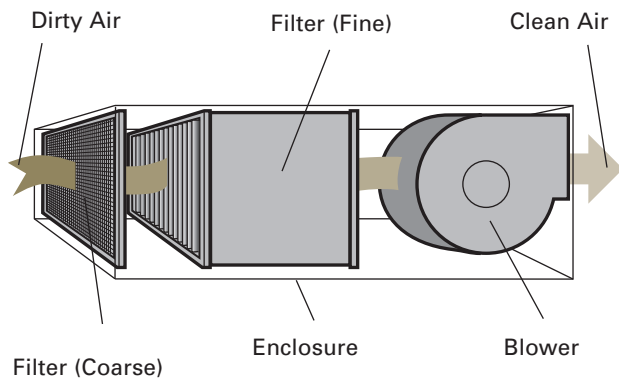

**High Operating Costs** The biggest drawback of media-type filtration systems is the high operating cost associated with replacement filters. Because these filters are designed to retain contaminants, they will become clogged with use. Usually they are made from media that cannot be cleaned, so the only alternative is replacement. Depending upon the cost of the filters and the replacement frequency, **this type of system can be quite expensive to operate over the long term.**

**Decreased Throughput** Another problem with multi-stage filter units is that the throughput of the system, measured in cfm, decreases as contaminants become trapped in the pores of the filters. It is important to maintain the correct throughput of any collection system. Reduced throughput means reduced collection, allowing contaminants to escape into the shop air.

**Not for Mist** Most media filters are designed to collect dry pollutants such as smoke and dust. Exposure to coolant and oil mist may damage certain types of filter media.

# COMMON MIST COLLECTION METHODS

## Electrostatic Precipitators

Electrostatic precipitators use a blower to draw mist and smoke particles past an ionizer, which imparts a positive charge to them. They then pass across a series of alternately like-charged and grounded collection plates. The particles are repelled by the like-charged plates and forced towards the grounded plates where they collect. The filtered air is returned to the shop.

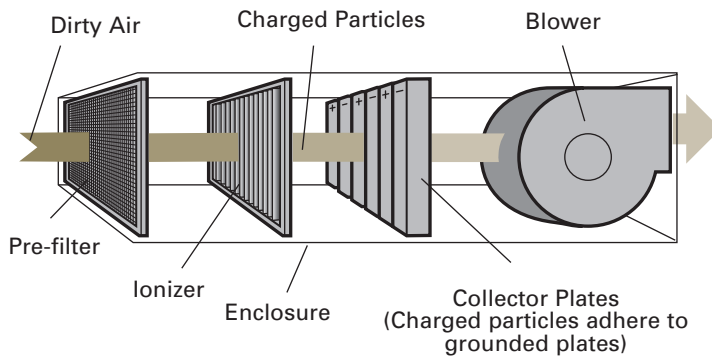

**Variable Efficiency** Although electrostatic systems are very efficient when the collection plates are clean, the efficiency drops off drastically as the plates become covered with particles. Each time a particle deposits on a plate, it eliminates a spot for other particles to adhere to.

**Maintenance Costs** To maintain high efficiency, the collection plates must be cleaned often. This can be expensive because the residue is considered to be hazardous waste and must be disposed of by a certified waste handling company. Many electrostatic systems are sold with costly maintenance contracts, resulting in operating costs that greatly exceed the original unit purchase price.

**Health Hazards** As the collection plates become full, a phenomenon known as arcing can occur. This arcing results in the **production of ozone**, which has been found to cause a variety of health problems. This potential danger (and the fear of lawsuits) has caused many U.S. companies to remove electrostatic units from their factories.

## The Dangers of Ozone

**Ozone produced by electrostatic precipitators presents a significant health risk to humans.** Here's what OSHA and the EPA have to say about ozone on their websites:

### OSHA

Ozone is highly injurious and potentially lethal to experimental animals at concentrations as low as a few parts per million (ppm). A study in which young mice were exposed to 1 ppm ozone for 1 or 2 days reported damage to alveolar tissue. Human populations chronically exposed to lower concentrations of ozone were observed to have adverse changes in lung function. Human volunteers exposed to 0.5 ppm ozone for 3 hours per day, 6 days per week, for 12 weeks showed significant adverse changes in lung function. Another report showed a 20 percent reduction in timed vital lung capacity in persons exposed to average concentrations of ozone of 1.5 ppm for 2 hours. <http://www.osha.gov/dts/sltc/methods/inorganic/id214/id214.html>

### EPA

Breathing ozone can trigger a variety of health problems including chest pain, coughing, throat irritation, and congestion. It can worsen bronchitis, emphysema, and asthma. "Bad" ozone also can reduce lung function and inflame the linings of the lungs. Repeated exposure may permanently scar lung tissue. <http://www.epa.gov/oar/oaqps/gooduphigh/>

**With these health (and potential lawsuit) risks, many companies have established policies that ban the use of electrostatic mist collectors in their facilities.**