

MODEL FX-275



- Used primarily on small, enclosed CNC machines with an internal volume of up to 80 cu. ft.
- Large 6" dia. intake results in a **very low intake velocity**, reducing the likelihood that chips and large droplets will be drawn into the unit.
- The model FX-275 comes complete with a collar seal, mounting hardware, and 5 ft. of oil return hose.
- Designed primarily for direct-mounting to the top of a machine, but stands and brackets are also available for applications where direct-mounting is not possible.
- Stainless steel model available for special applications.

FX-275 Specifications

Airflow	275 cfm
Fits machines with enclosure volume of:	Up to 80 cubic feet
Motor	3/4 HP, 3-Phase, 50/60 Hz. Voltage & Current @ 60Hz: 208V - 2.7A 230V - 2.5A 460V - 1.3A
Weight	31 lbs.
Noise Level	65 dBA
Inlet Diameter	6"

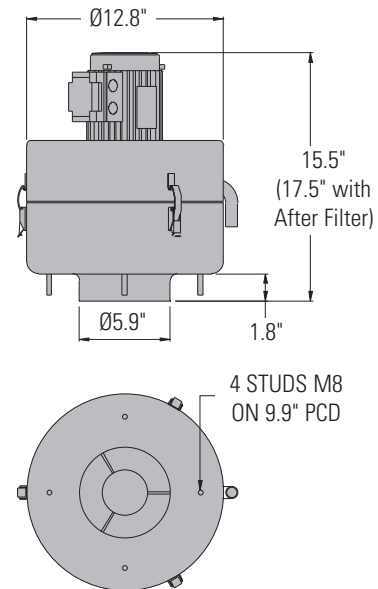

Mounting Options — FX-275

Mounting Option	Hardware included with Filtermist Unit
Direct Mount	Hardware included with Filtermist Unit
Floor Stand	use 30316 — Floor Stand "A"
Machine Top Stand	N/A
Wall Mount	use 30328 — Wall Bracket "A"
Machine Side Mount	use 30330 — Side-Mount Bracket "A"
Suspended	N/A



MODEL FX-275



Filtermist Units

DESCRIPTION	PART NUMBER	PRICE
 FX-275 Filtermist Unit Includes collar seal and all necessary hardware to mount unit directly to the top of a machine. Also includes 5 ft. of oil return hose.	30100	\$1,665
 FX-275 Stainless Steel Unit See page 134 for additional information.	30140	\$3,180

Electrical Accessories

DESCRIPTION	PART NUMBER	PRICE
 Starter Box Kit Includes NEMA 12 box, IEC motor starter, 20 ft. of input cable, 15 ft. of output cable with turn-lock connector	FX-275 & 550 Low-Voltage (208/230V) 30470 FX-275 & 550 High Voltage (460V) 30471	\$450 \$450









Performance Accessories

DESCRIPTION	PART NUMBER	PRICE
 After Filter "A" Used for collecting dry smoke and very fine mist particles.	30200	\$258
 Chip Deflector "A" Protects intake from coolant splash and chips.	30222	\$48



Check out the Royal Filtermist Video at www.mistcollectors.com

Mounting Accessories

Description	PART NUMBER	PRICE
 Side Mounting Bracket "A" Allows unit to be mounted to the side of a machine tool. Include hardware and chip deflector.	30330	\$261
 Floor Stand "A" Fixed height of 6 ft. Bolts to floor for safety.	30316	\$415
 Wall Bracket "A" For mounting unit to a wall or side of a machine.	30328	\$143
 Oil Return Hose 3/4" diameter.	30335	\$4/ft.
 Ducting Flexible vinyl with heavy wire support.	8" 30344 6" 30342 4" 30340	\$13/ft. 10/ft. 9/ft.
Warning — never use sheetmetal ducting or any other type that could leak and cause a hazardous condition.		
 Hose Clamps For securing ducting to accessories.	8" 30354 6" 30352 4" 30350	\$5/ft. 5/ft. 4/ft.
 Y-Junctions For multiple pickup locations.	A B 8" 6" 30368 8" 4" 30366 6" 6" 30364 6" 4" 30362 4" 4" 30360	\$255 315 234 225 184
 Flange Adapters For securing ducting directly to an enclosed machine.	8" 30374 6" 30372 4" 30370	\$55 53 50
 Reducers	A B 8" 6" 30382 6" 4" 30380	\$97 97
 Fishtails For use on open machines.	A B 8" 11.75" x 5" 30394 6" 10" x 4.5" 30392 4" 8.25" x 3.5" 30390	\$184 166 153