

MODEL FX-550



- Replaces model FX-600.
- For use on enclosed machines with an internal volume between 60 cu. ft. and 120 cu. ft.
- **Well suited to many swiss-style CNC's** and screw machines.
- Designed primarily for direct-mounting to the top of a machine, but stands and brackets are also available for applications where direct-mounting is not possible.
- Stainless steel model available for special applications.

FX-550 Specifications

Airflow	550 cfm
Fits machines with enclosure volume of:	60–120 cubic feet
Motor	3/4 HP, 3-Phase, 50/60 Hz. Voltage & Current @ 60Hz. 208V – 2.7A 230V – 2.5A 460V – 1.3A
Weight	35 lbs.
Noise Level	67 dBA
Inlet Diameter	6"

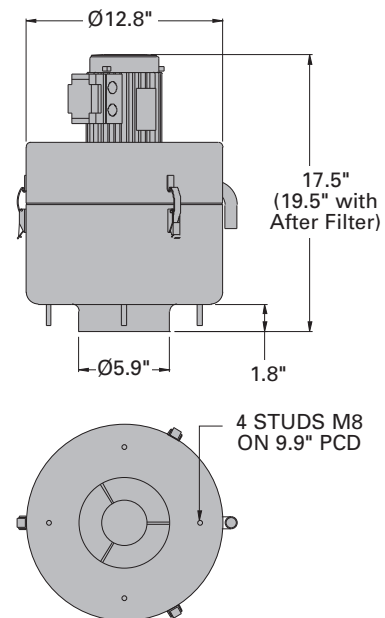

Mounting Options — FX-550

Direct Mount	Hardware included with Filtermist Unit
Floor Stand	use 30316 — Floor Stand "A"
Machine Top Stand	N/A
Wall Mount	use 30328 — Wall Bracket "A"
Machine Side Mount	use 30330 — Side-Mount Bracket "A"
Suspended	N/A



MODEL FX-550



Filtermist Units

Description	Cat. No.	Price
 FX-550 Filtermist Unit Includes collar seal and all necessary hardware to mount unit directly to the top of a machine. Also includes 5 ft. of oil return hose.	30108	\$1,895
 FX-550 Stainless Steel Unit See page 134 for additional information.	30180	\$3,375

Electrical Accessories

Description	Cat. No.	Price	
 Starter Box Kit Includes NEMA 12 box, starter, 20 ft. of input cable, 15 ft. of output cable with turn-lock connector	FX-275 & 550 Low-Voltage (208/230V) FX-275 & 550 High Voltage (460V)	30470 30471	\$429 \$429











Performance Accessories

Description	Cat. No.	Price
 After Filter "A" Used for collecting dry smoke and very fine mist particles.	30200	\$218
 Chip Deflector "A" Protects intake from coolant splash and chips.	30222	\$46



Check out the Royal Filtermist Video at www.mistcollectors.com

Mounting Accessories

Description	Cat. No.	Price	
 Side Mounting Bracket "A" Allows unit to be mounted to the side of a machine tool. Includes hardware and chip deflector.	30330	\$249	
 Floor Stand "A" Fixed height of 6 ft. Bolts to floor for safety.	30316	\$395	
 Wall Bracket "A" For mounting unit to a wall or side of a machine.	30328	\$136	
 Oil Return Hose 3/4" diameter.	30335	\$3 per ft.	
 Ducting Flexible vinyl 8" with heavy wire 6" support. 4"	30344 30342 30340	\$12 per ft. \$9 per ft. \$8 per ft.	
Warning — never use sheetmetal ducting or any other type that could leak and cause a hazardous condition.			
 Hose Clamps For securing ducting to accessories.	8" 6" 4"	30354 30352 30350	\$5 \$5 \$4
 Y-Junctions For multiple pickup locations.	A B 8" 6" 8" 4" 6" 6" 6" 4" 4" 4"	30368 30366 30364 30362 30360	\$243 \$300 \$223 \$214 \$175
 Flange Adapters For securing ducting directly to an enclosed machine.	8" 6" 4"	30374 30372 30370	\$52 \$50 \$48
 Reducers	A B 8" 6" 6" 4"	30382 30380	\$92 \$92
 Fishtails	A B For use on open machines. 8" 11.75" x 5" 6" 10" x 4.5" 4" 8.25" x 3.5"	30394 30392 30390	\$175 \$158 \$146