

MODEL FX-900



- For use on enclosed machines with an internal volume between 90 cu. ft. and 180 cu. ft.
- **Popular for open machines** requiring a Y-junction and two intake points.
- Unit can be mounted directly to the machine, on stands, on brackets, or suspended.

FX-900 Specifications

Airflow	900 cfm
Fits machines with enclosure volume of:	90–180 cubic feet
Motor	3 HP, 3-Phase, 50/60 Hz. Voltage & Current @ 60Hz. 208V – 8.8A 230V – 8.2A 460V – 4.1A
Weight	51 lbs.
Noise Level	70 dBA
Inlet Diameter	6"

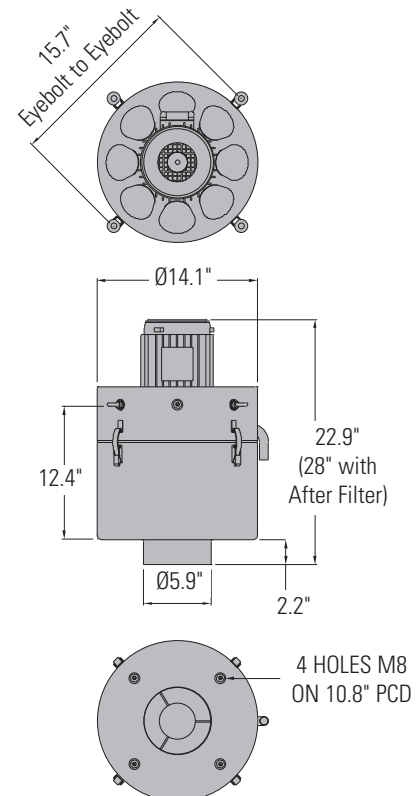

Mounting Options — FX-900

Direct Mount	use 30302 — FX-900 Direct Mount Kit
Floor Stand	use 30315 — Floor Stand "B"
Machine Top Stand	use 30314 — Machine Stand "B"
Wall Mount	use 30320 — Wall Bracket "B"
Machine Side Mount	N/A
Suspended	use 30310 — Suspension Kit "B"



MODEL FX-900

Filtermist Units

DESCRIPTION	PART NUMBER	PRICE
 FX-900 Filtermist Unit Order performance and mounting accessories separately.	30120	\$2,565
 FX-900 Stainless Steel Unit See page 134 for additional information.	30160	\$4,055

Electrical Accessories

DESCRIPTION	PART NUMBER	PRICE
 Starter Box Kit Includes NEMA 12 box, IEC motor starter, 20 ft. of input cable, 15 ft. of output cable with turn-lock connector	FX-900 & 1200 Low-Voltage (208/230V)	30472 \$450
	FX-900 & 1200 High Voltage (460V)	30473 \$450

Performance Accessories

DESCRIPTION	PART NUMBER	PRICE
 After Filter "B" Used for collecting dry smoke and very fine mist particles.	30205	\$274
 Cyclonic Swarf Separator For use on applications such as grinding and cast iron machining where very fine solid particles are entrained in the mist stream. Also acts as a great pre-filter for high pressure coolant applications.	30210	\$697
 Chip Deflector "B" Protects intake from coolant splash and chips.	30220	\$48

Mounting Accessories

DESCRIPTION	PART NUMBER	PRICE												
 Direct Mount Kit (FX-900) Includes 6" collar seal, set of rigid mounting studs, and hardware.	30302	\$69												
 Floor Stand "B" Adjusts from 6 ft. to 9 ft. Bolts to floor for safety.	30315	\$730												
 Machine Top Stand "B" 3 ft. tall stand bolts to the top of a machine.	30314	\$383												
 Wall Bracket "B" Can be used to mount unit to a wall or other suitable mounting surface.	30320	\$257												
 Suspension Kit "B" Includes 30 ft. of chain, 4 eyebolts, 8 split links, and 1 adjustable link.	30310	\$109												
 Oil Return Hose 3/4" diameter.	30335	\$4/ft.												
 Ducting Flexible vinyl with heavy wire support.	8" 30344 6" 30342 4" 30340	\$13/ft. 10/ft. 9/ft.												
Warning — never use sheetmetal ducting or any other type that could leak and cause a hazardous condition.														
 Hose Clamps For securing ducting to accessories.	8" 30354 6" 30352 4" 30350	\$5/ft. 5/ft. 4/ft.												
 Y-Junctions For multiple pickup locations.	<table border="1"> <tr> <th>A</th> <th>B</th> </tr> <tr> <td>8"</td> <td>6"</td> </tr> <tr> <td>8"</td> <td>4"</td> </tr> <tr> <td>6"</td> <td>6"</td> </tr> <tr> <td>6"</td> <td>4"</td> </tr> <tr> <td>4"</td> <td>4"</td> </tr> </table>	A	B	8"	6"	8"	4"	6"	6"	6"	4"	4"	4"	30368 \$255 30366 315 30364 234 30362 225 30360 184
A	B													
8"	6"													
8"	4"													
6"	6"													
6"	4"													
4"	4"													
 Flange Adapters For securing ducting directly to an enclosed machine.	8" 30374 6" 30372 4" 30370	\$55 53 50												
 Reducers	<table border="1"> <tr> <th>A</th> <th>B</th> </tr> <tr> <td>8"</td> <td>6"</td> </tr> <tr> <td>6"</td> <td>4"</td> </tr> </table>	A	B	8"	6"	6"	4"	30382 \$97 30380 97						
A	B													
8"	6"													
6"	4"													
 Fishtails For use on open machines.	<table border="1"> <tr> <th>A</th> <th>B</th> </tr> <tr> <td>8"</td> <td>11.75" x 5"</td> </tr> <tr> <td>6"</td> <td>10" x 4.5"</td> </tr> <tr> <td>4"</td> <td>8.25" x 3.5"</td> </tr> </table>	A	B	8"	11.75" x 5"	6"	10" x 4.5"	4"	8.25" x 3.5"	30394 \$184 30392 166 30390 153				
A	B													
8"	11.75" x 5"													
6"	10" x 4.5"													
4"	8.25" x 3.5"													