

5C PNEUMATIC COLLET CLOSER FOR MANUAL LATHES & GRINDERS

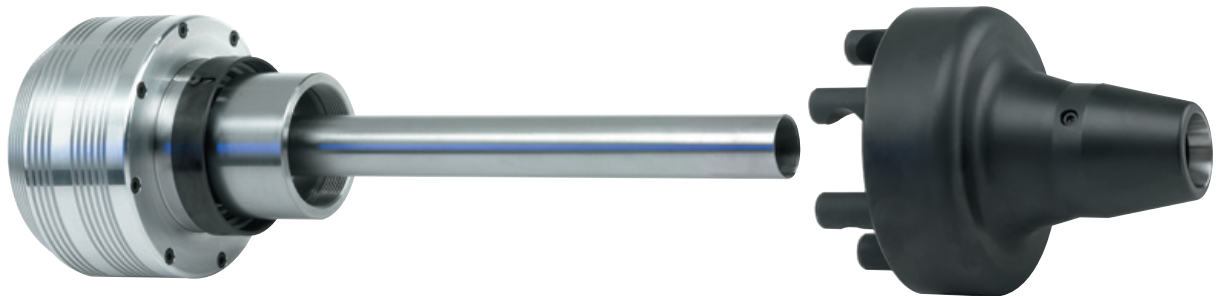

- ❑ The Royal 5C pneumatic collet closer enables 5C collets to be used on any manual lathe or workhead.
- ❑ This new model, based upon Royal's 50+ years of collet closer experience, has been designed for heavy use under the most demanding manufacturing conditions.
- ❑ Fast opening/closing action makes the Royal pneumatic collet closer a great choice for **high production** applications.
- ❑ Closer is very easy to actuate, resulting in minimal worker fatigue and maximum productivity.
- ❑ The air cylinder incorporates a large diameter piston, providing strong grip force on the workpiece.
- ❑ Royal 5C Pneumatic Collet Closer incorporates several modern safety features designed to help shops meet **OSHA and NIOSH** requirements. Unlike other collet closers, there are no exposed rotating parts on the outboard side of the machine.
- ❑ Pneumatic collet closer assembly includes air cylinder, custom-machined rear end spindle adapter, drawtube, and cam-lock collet adapter. Air controls sold separately.

Drawtube Capacity (inches)	1.06
Cylinder O.D. (in.)	5.94
Max. Operating Speed (rpm)*	4,000*
Max. Air Pressure (psi)	90
Piston Surface Area (sq. in.)	14.72
Max. Drawtube Force (lbs.)	1,325
Max. Clamping Force (lbs.)	4,520

* For continuous operation above 3,000 rpm we recommend reducing air pressure to 60 psi max.

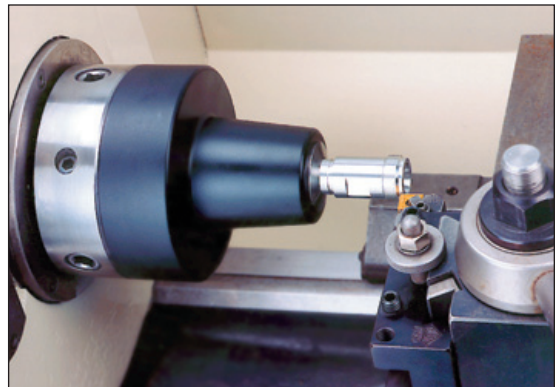

5C PNEUMATIC COLLET CLOSER FOR MANUAL LATHES & GRINDERS

Cooling fins dissipate heat, resulting in longer bearing life.

Sliding guard protects operator by preventing contact with rotating components.

Easy Setup — Collet changes take place at the spindle nose.

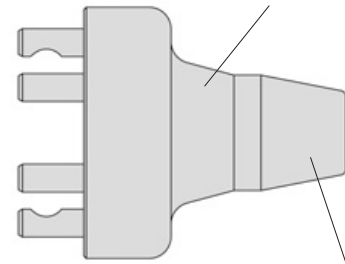
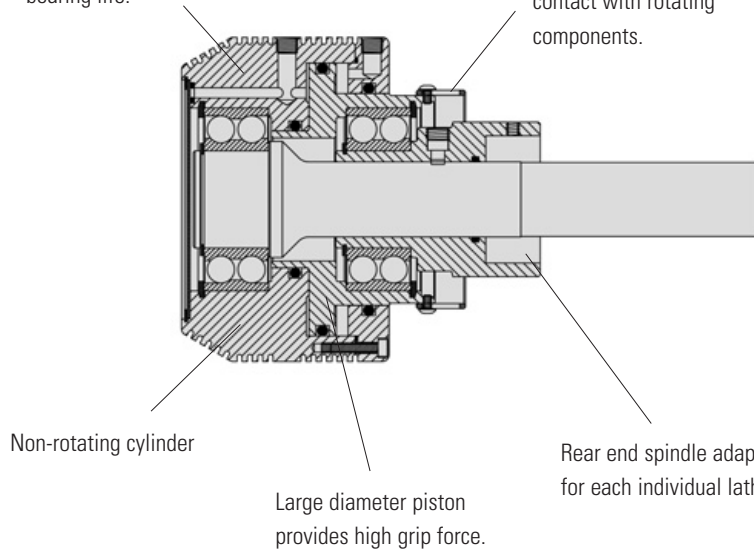

0.0003" TIR Guaranteed

Non-rotating cylinder

Large diameter piston provides high grip force.

Rear end spindle adapter is **custom-machined** for each individual lathe.

Royal 5C Pneumatic Collet Closer Assembly

FOR LATHES WITH SPINDLE NOSE TYPE	CATALOG NUMBER	PRICE
A-3 or D1-3	17200	\$1,842
A-4 or D1-4	17201	1,930
A-5 or D1-5	17202	2,122
A-6 or D1-6	17203	2,313
A-8 or D1-8	17204	2,642
Haas TL-1*	17210	1,968
Haas TL-2*	17211	2,122

* Haas TL-1 and TL-2 are registered trademarks of Haas Automation, Inc.

Order Air Controls Separately

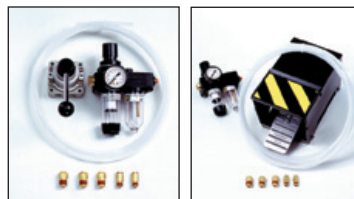

DESCRIPTION	CATALOG NUMBER	PRICE
Air Control Kit w/Hand Valve	16001	\$271
Air Control Kit w/Foot Valve	16002	426